

# **INTELLIMETER®**

## **MODELS A, AB, R2 AND PM2**

### **INSTALLATION AND CONNECTIONS**

### **INSTRUCTION MANUAL**

**WARNING:** Any work on or near energized metering equipment can present a danger of electrical shock. All work on these products should be performed only by qualified industrial electricians and metering specialist in accordance with the local utility safety practices and procedures outlined in the Handbook for Electricity Metering (available from the Edison Electric Institute, 1111 19th St. NW, Washington, DC 20036). The information contained within this book is intended to be an aid to qualified metering personnel. It is not intended to replace the extensive training necessary to install or remove meters from service.

Document A-7004-44 Rev-G  
Drawing B902-444

June 28, 2005

# ***OSC/INTELLIMETER***

1051 SERPENTINE LANE, STE. 400  
Phone (925) 485-9490

PLEASANTON, CA 94566  
Fax (925) 485-9537

## INTRODUCTION

The Intellimeter models A, AB, R2 and PM2 are component parts of a system designed to measure electrical energy and communicate the measurements to a central station using powerline carrier signals over the power lines. The models A and AB are single and dual input watthour meters. The model R2 is a repeater which retransmits system messages over the powerline. The model PM2 is a dual channel pulse monitor which accepts pulse input signals from water meters, gas meters, watthour meters or any other metering device with a pulse output. The PM2 receives, counts and transmits the pulse information to the system central station using powerline carrier communication.

Detailed setup and programming instructions are in the Intellimeter Field Programming Instructions (Document A-7004-22).

**Warning:** If the equipment described is modified or used in any manner not specified by these instructions the protection provided by the equipment may be impaired.

<u>MODEL</u>	<u>FUNCTION</u>	<u>ELECTRICAL RATING</u>
A-120	Watthour Meter Single Channel	120Vac <sup>1</sup>
AB-120	Watthour Meter Dual Channel	120Vac <sup>1</sup>
R2-120	Repeater	120Vac <sup>1</sup>
PM2-120	Pulse Monitor Dual Channel	120Vac <sup>1</sup>
A-277	Watthour Meter Single Channel	277Vac <sup>2</sup>
AB-277	Watthour Meter Dual Channel	277Vac <sup>2</sup>
R2-277	Repeater	277Vac <sup>2</sup>
PM2-277	Pulse Monitor Dual Channel	277Vac <sup>2</sup>
A-346	Watthour Meter Single Channel	346Vac <sup>3</sup>
AB-346	Watthour Meter Dual Channel	346Vac <sup>3</sup>
R2-346	Repeater	346Vac <sup>3</sup>
PM2-346	Pulse Monitor Dual Channel	346Vac <sup>3</sup>

### OPTIONS

D	Display
SM	Surface Mount
FM	Flush Mount

E.G. AB-277-SM-D

<sup>1</sup> 120Vac (Line to Neutral) for use on the following type electrical service

120Vac	2-Wire Single-Phase
120/208Vac	3-Wire Network
120/240Vac	3-Wire Single-Phase Edison
120/208Vac	Three-phase, 4-Wire

<sup>2</sup> 277Vac (Line to Neutral) for use on 277/480Vac three-phase, 4-wire electrical service

<sup>3</sup> 346Vac (Line to Neutral) for use on 346/600Vac three-phase, 4-wire electrical service

# INTELLIMETER INSTALLATION AND CONNECTION INSTRUCTIONS

## SAFETY NOTES

Working clearances should comply with NEC Article 110-16. If not, take corrective action. The Intellimeter is intended for **indoor use only**. Do not install in damp or wet location. Wire bending space should be in compliance with NEC Article 373-6. Verify that current transformer (CT), potential tap and wiring can be installed without crowding subpanel. Verify that the current transformer can be installed with a minimum 1/2 inch clearance to uninsulated live parts in subpanel, and without bearing against dead metal parts. Verify that power is 120/208, 120/240, 277/480 or 346/600Vac.

1. If flush mounting, cut a hole in the wall adjacent to the subpanel for 8 by 10 inch Intellimeter enclosure.

**NOTE:** Equipment grounding must be done in accordance with local and national codes of the authority having jurisdiction. A protective earth terminal is provided for this function.

2. Secure 3/4 inch metal conduit or flexible metal conduit to subpanel. Use insulating bushing. Locknuts must be tightened enough to pierce paint in cabinet.
3. Secure Intellimeter enclosure in or on wall; wall stud or equivalent support is required.

**NOTE:** When flush mounting, the edge of the enclosure is to be flush with the edge of the wall. When surface mounting, use suitable means for mounting.

4. Run CT leads, potential leads and neutral lead from cabinet to Intellimeter enclosure. Use a maximum size #14 AWG THHN stranded and make all three wire harnesses a minimum of 10 inches long, otherwise you will have difficulty plugging in the 1 ea. 4 position connector and the 2 ea. 6 position connectors. See Figure 8.
5. Cut leads to size and strip 1/4" insulation off ends. No uninsulated wire should be showing outside the connector. Identify leads with numbered tags at each end of wire within three inches of termination and current transformer. ID is to be visible after installation.
6. Connect voltage leads to the four position connector PL 11 as shown in Figure 1. Label each set of CT leads with the load/tenant ID. Connect single load meter CTs to PL4 (PL5 not used). Two load meters use PL4 and PL5. See Figure two for CT connections and polarity. Use Figures 5, 6, 7 and 8 for load connections.

**VERY IMPORTANT:** Record on the Installation Specification Sheet and write on the blank label provided for the enclosure cover, the “load/tenant ID” you are plugging into PL4 “the A DIAL” and “load/tenant ID” you are plugging into PL5 “the B DIAL”. For the label, use a indelible black marker.

**NOTE:** Intellimeters use terminal 1 for powerline carrier communications. Whenever possible, use Phase A for terminal 1 on all meters and low voltage service couplers. Low voltage service couplers are required to establish communication paths around transformers, between separate services, etc.

7. Turn off all breakers in cabinet. Check all loads for voltage.
8. Disconnect power to subpanel. Have temporary lighting at hand, if required.
9. Remove feeders from lugs and place feeder cables through current transformers with **current flow arrows pointed toward loads.**
10. Replace feeders in the lugs and tightly secure connections.
11. Secure CT’s on feeders at least 1/2 inch away from uninsulated live parts and not in contact with dead metal, using wire ties.
12. Connect potential leads to feeders on line side of current transformers using an approved method for making the tap.

Alternate: Route potential lead from input connector through the current transformer in the direction of the current flow arrow and connect to voltage on the load side of the current transformer.

For proper operation observe proper phasing between potential taps and current transformers.

13. Connect neutral lead to neutral bus.
14. Use wire ties to bundle Intellimeter wiring harness and route it away from other conductors in cabinet. Also bundle wiring harness in Intellimeter enclosure with wire ties before the electronic assembly is installed.
15. Secure cover on subpanel.
16. Install the Intellimeter electronic assembly (see Figure 9); insure electronic assembly is a “-120” meter for 120/208 or a “-277” meter for 277/480 or “-346” for 346/600 volt service. Adjust tamper switch if necessary. Plug the three input connectors into the proper headers labeled PL11, PL4 and PL5 . Observe the keying of the connectors.
17. If a local display is to be used, install display per Figure 9 before power is applied.
18. Reconnect power to the subpanel. Turn on the circuit breakers.

## **PULSE OUTPUT CONNECTIONS**

The Intellimeter provides a KYZ output pulse for both the A dial and B dial kilowatthours. These pulses can be used for load profile or demand side management. Each output is a solid state, Form C, contact rated at 350V peak and .120A maximum.

The A dial and B dial pulse is output on PL1 and PL2 respectively. The following is an explanation of the pulse value for the various models using Intellimeter 0.1A secondary current transformers.

<b>MODEL</b>	<b>K<sub>n</sub> TO 100:0.1 WH PULSE</b>	<b>K<sub>n</sub> FOR 200:0.1 WH PULSE</b>	<b>K<sub>n</sub> FOR 400:0.1 WH PULSE</b>
AB-120	1.2	2.4	4.8
AB-277	2.4	4.8	9.6
AB-346	3.36	6.72	13.44

Multiplier for meters using 5 Amp secondary rated current transformers with 10 turn prewrap on 100:01 Intellimeter current transformer can be calculated by dividing the primary rating by 50.

<b>PRIMARY RATING</b>	<b>MULTIPLIER</b>	<b>PRIMARY RATING</b>	<b>MULTIPLIER</b>
600	12	1200	24
800	16	1600	32
1000	20	2000	40

The new pulse value is the K<sub>n</sub> for the meter used times the multiplier for the 5 amp secondary current transformer used.

Full load pulse rate output is calculated as follows:

$$\begin{aligned}
 \text{Pulse Rate Max} &= \frac{V_n \times I_n \times 3}{K_h \times \text{MULT}} \\
 &= \frac{277 \times 600 \times 3}{2.4 \times 12} && \text{For 277/480 Volt Service} \\
 &&& \text{Using 600:5 CT's} \\
 &= 17,312.5 \frac{\text{Pulses}}{\text{Hour}} && \text{@ Full Scale of 498, 600 Watts}
 \end{aligned}$$

The addition of a potential transformer will require a second multiplier equal to the value of the PT ratio (primary/secondary).

## **SPECIFICATIONS**

Voltage:	Nominal $\pm 10\%$ , 50/60Hz, 9 watts Nominal (Line-To-Neutral) 120, 277, 346 Installation Overvoltage Category III Pollution Degree 2
Power Factor:	Accurate at any
Temperature:	-20°C to +50°C
Altitude:	Up to 2,000m
Humidity:	Maximum relative humidity 80% for temperatures up to 31°C decreasing linearity to 50% relative humidity at 40°C
Accuracy:	Exceeds ANSI C12.16
Memory:	Nonvolatile EE PROM
Communications:	Power Line Carrier, 36.8 KHZ, Phase Modulation
Burdens:	9VA max overall, 0.1 VA per current input
Approvals:	UL/CUL to 3111, FCC Part 15 Class B
Enclosure:	8"W x 10"H x 3"D
Current Transformers:	0.1 amp secondary output
Pulse Output:	Form C or Form A contacts rated at 0.1amp 240Vac
Options:	Readout LCD Display Backlighted "D" Surface Mount "SM" or Flush Mount "FM"
Cleaning:	The meters are not suitable for hose down cleaning. Use only a damp cloth to remove dust or dirt from the outside of the enclosure.

# INTELLIMETER INPUT AND OUTPUT CONNECTORS

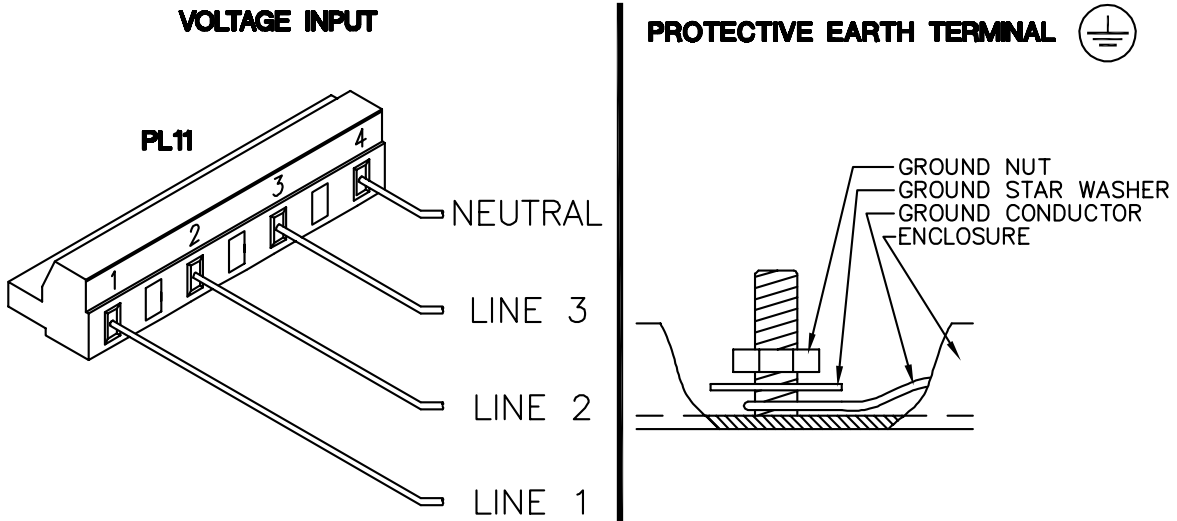

FIGURE 1

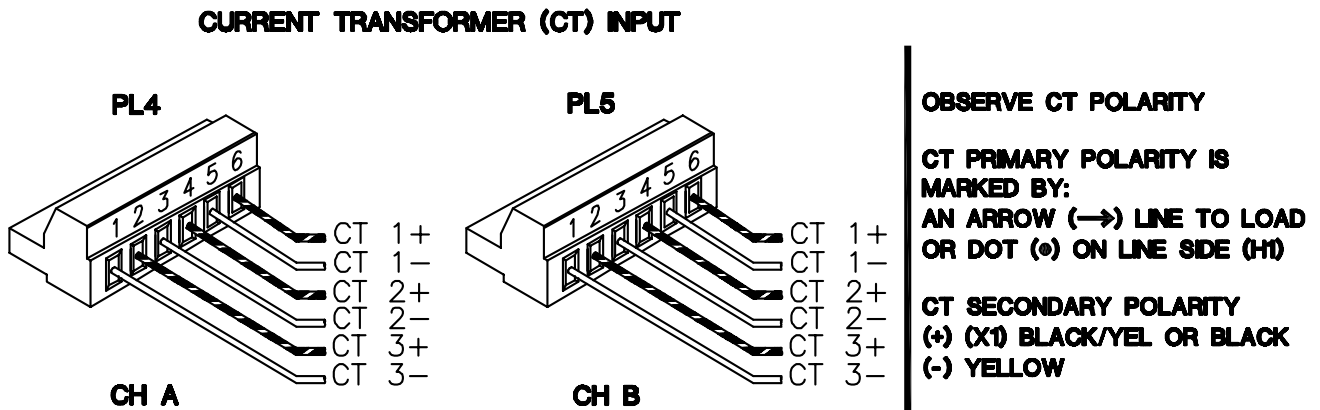

FIGURE 2

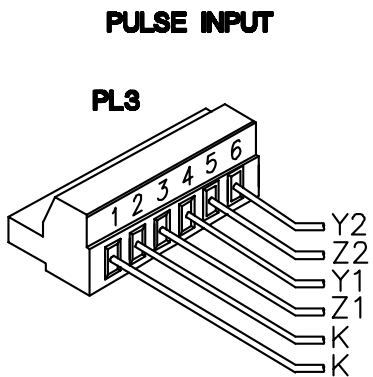

FIGURE 3

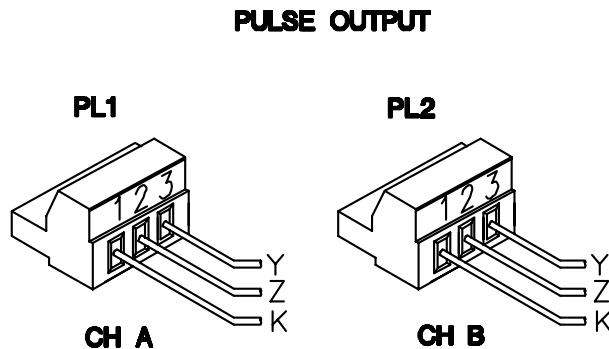
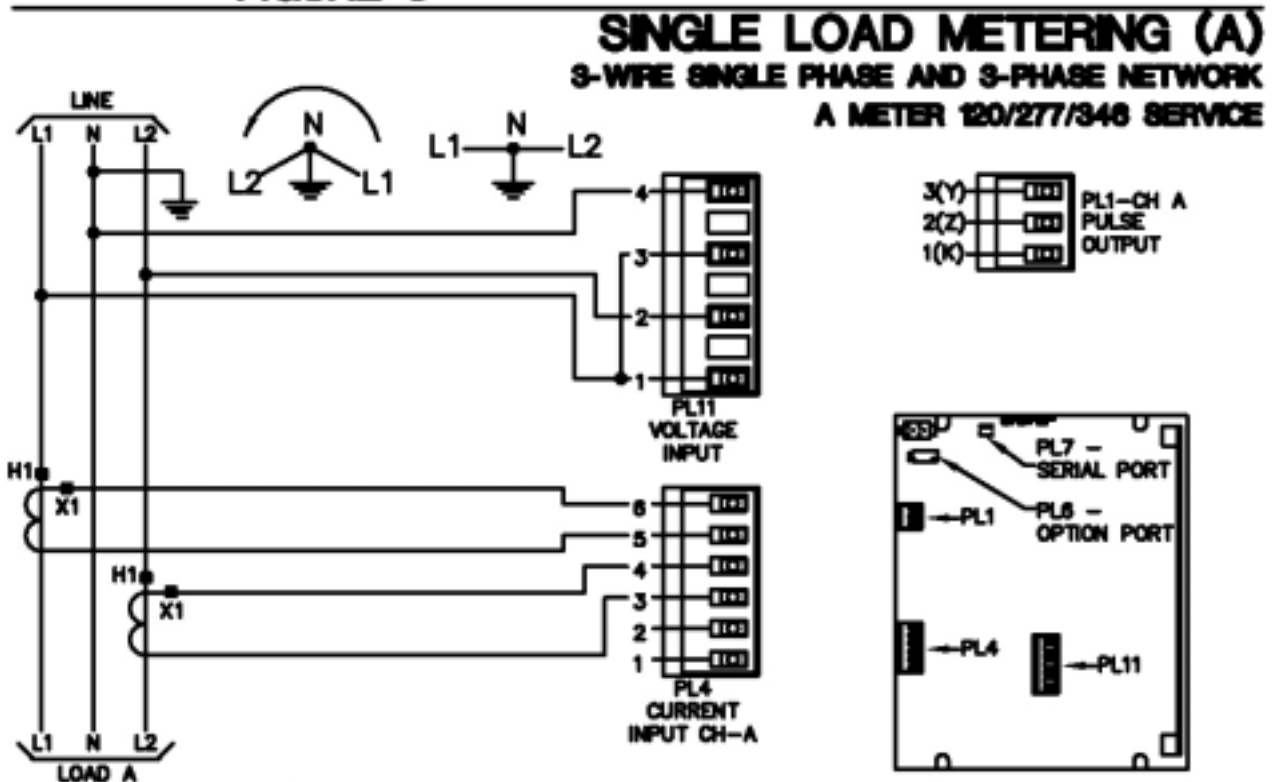
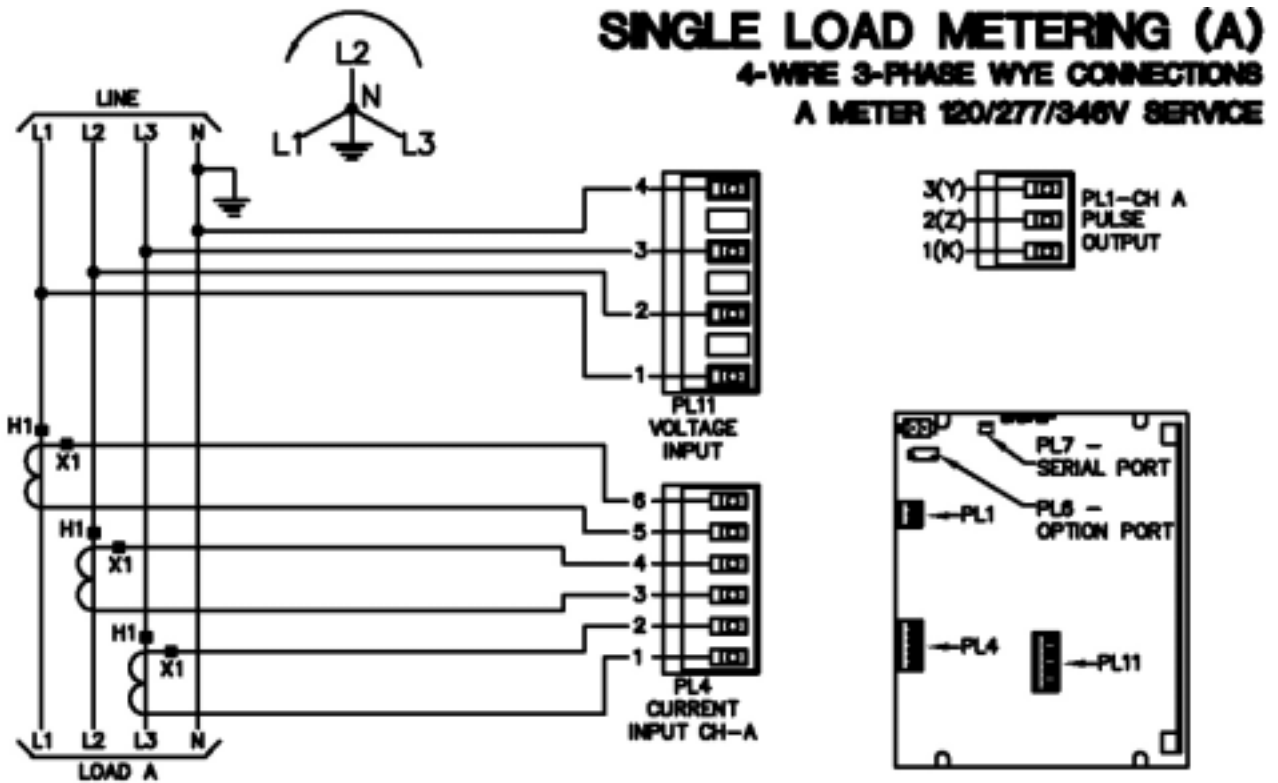

FIGURE 4



## TWO LOAD METERING (AB)

4-WIRE 3-PHASE WYE CONNECTIONS

AB METER 120/277/346V SERVICE

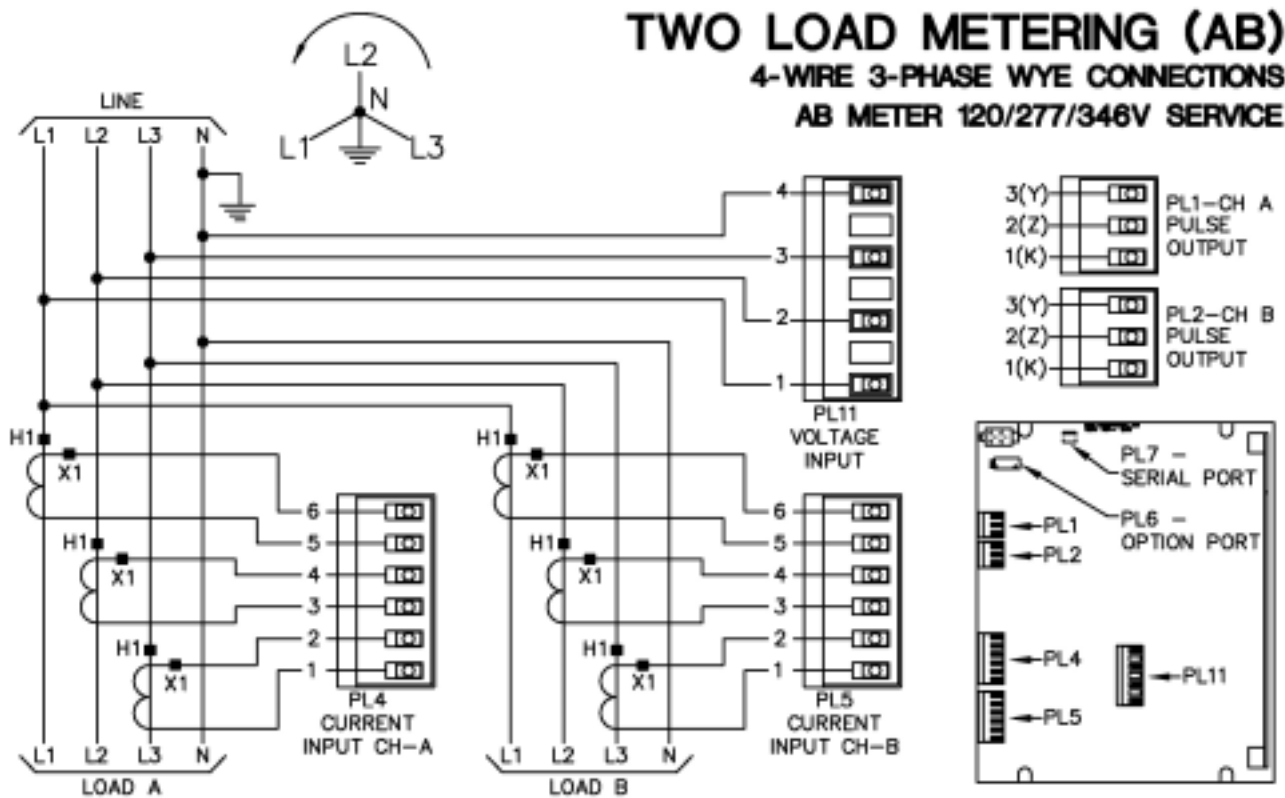

FIGURE 7

## TWO LOAD METERING (AB)

3-WIRE SINGLE PHASE AND 3-PHASE NETWORK

AB METER 120/277/346V SERVICE

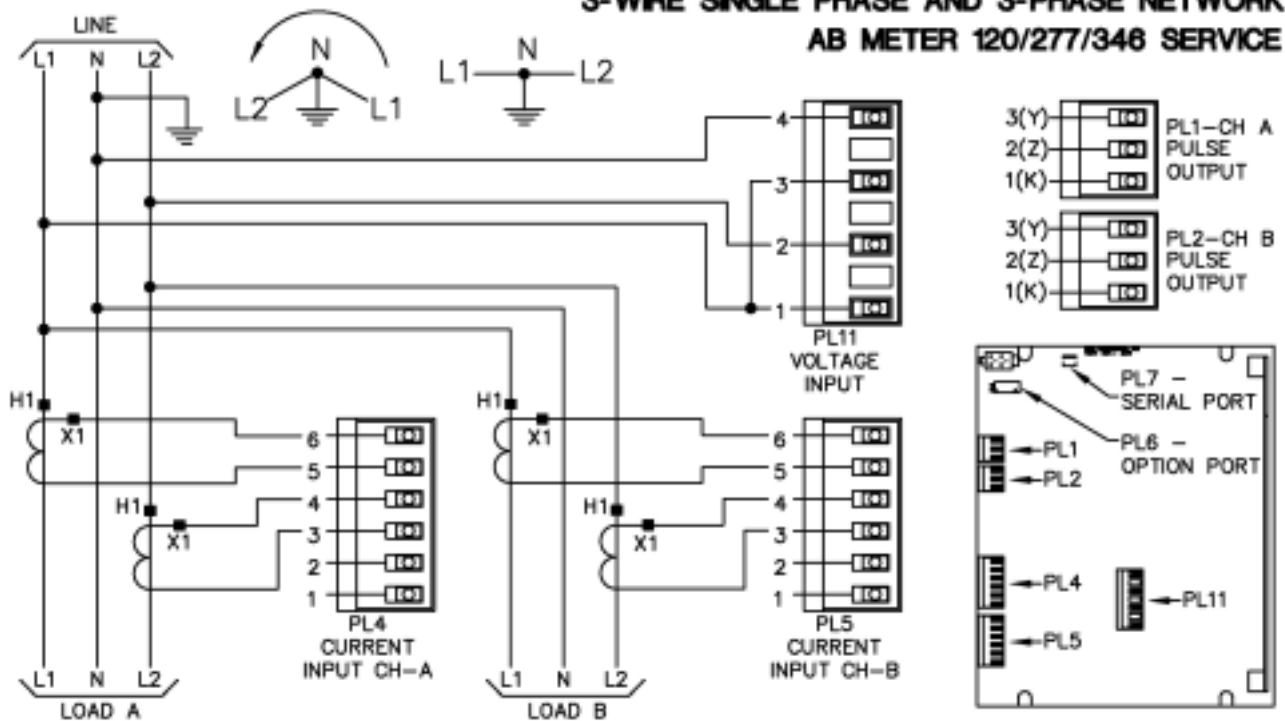
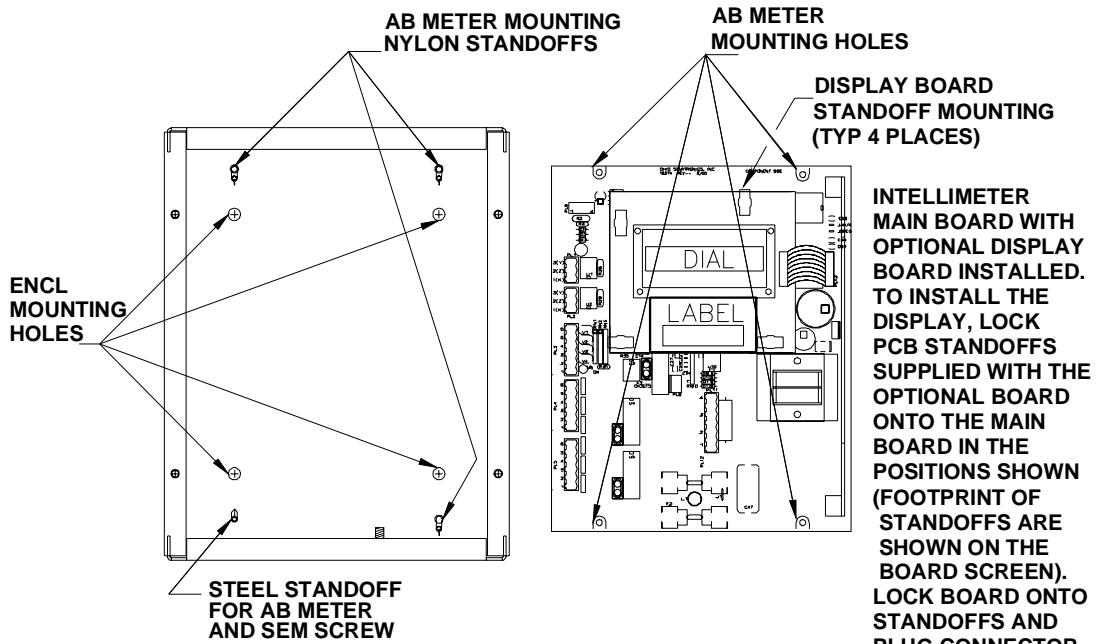
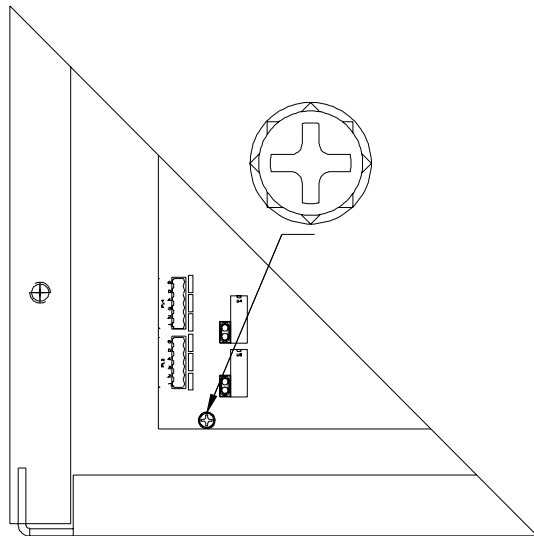

FIGURE 8

## ENCLOSURE ASSEMBLY



**STEP 1: INSTALL AB METER BOARD IN ENCLOSURE BY LINING UP NYLON STANDOFFS WITH BOARD MOUNTING HOLES IN THE DIRECTION SHOWN ABOVE AND PRESSING BOARD DOWN ONTO NYLON STANDOFFS UNTIL THEY LOCK.**



**FIGURE 9**

## **MAINTENANCE**

**Routine Maintenance:** There are no required maintenance operations for the Intellimeters. However, qualified personnel may wish to perform an annual inspection of wiring connections.

**Repairs:** It is not recommended that the field personnel replace any of the internal components, including fuses. If it is necessary to replace an Intellimeter, qualified personnel should follow the procedure below:

Have replacement board available before starting procedure. Disconnect power from the metered load and the meter. Remove the cover from the Intellimeter. Unplug the Connectors. Intellimeter current transformers have internal electronic shorting switches and will not be damaged by being left in an open circuit condition.

Replace the electronic assembly (refer to installation instructions on page 3). Return the electronics assembly to the dealer or distributor from whom it was purchased for replacement.